

# JVC<sup>®</sup>

Full HD 3D Memory Card Camcorder

# GY-HMZ1E

## ProHD

# 3D

Professional



AVCHD

SD  
XC

HDMI<sup>®</sup>  
HIGH DEFINITION MULTIMEDIA INTERFACE

*Full HD, 24p Compatible, Twin-lens 3D Camcorder  
for Professional 3D Production*

# 3D Professional

## From Acquisition to Editing, 24p Compatible 3D Recording that Meets the Needs of Professionals

Answering the needs of professional users for flexibility and image quality, the JVC GY-HMZ1E enables super bright 3D capture at Full HD resolution in a range of formats, including 24p. Compatibility with existing production systems is maintained thanks to JVC's unique L/R Independent format as well as the widely used Side-by-Side format. Supplied software splits the 3D file into separate left and right image files for Non-Linear Editing workflow support.

## Twin Left and Right Imaging Lenses and Back-illuminated CMOS Sensors

### JVC 3D TWIN HD GT LENS

Designed by JVC and manufactured to strict quality standards, the Twin HD GT Lens features several aspherical lenses and extra-low dispersion glass to minimise chromatic aberration caused by light refraction for sharp, high-contrast images even at the edges of the frame. The result is an industry-leading super bright F1.2 lens that delivers a remarkable level of detail and clarity, resulting in stunning 3D images.

### Fully synchronised 5-times optical zoom in 3D mode

#### 1/4" 3.3M Back-illuminated CMOS Sensors

Twin Back-illuminated CMOS Sensors capture high-resolution images with superior low-light performance.

### New Automatic Stabilisation System

Automatic stabilisation corrects the image displacement of the twin lenses and stabilises the optical axis, resulting in smoother 3D images, even when using the 5x optical zoom.

#### Parallax Adjustment

A unique JVC algorithm automatically adjusts parallax, altering the 3D convergence point according to the distance of the subject from the lens. Manual adjustment is also possible.



## Capture

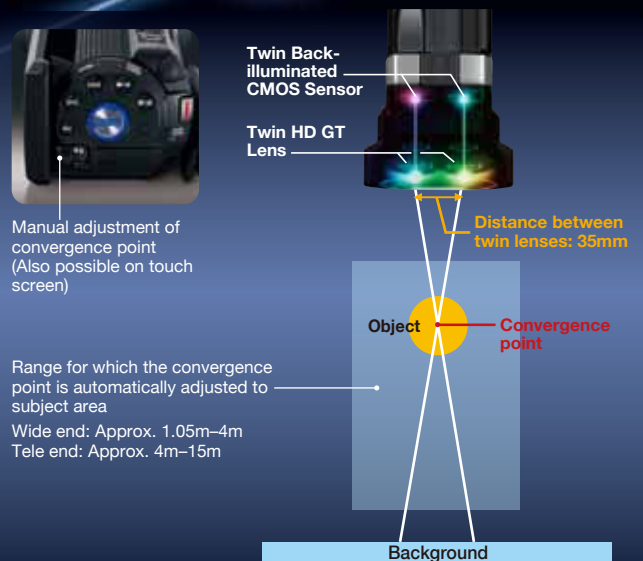

\* The above values are in the case of a level white background and are not guaranteed.



## Record

A Flexible Solution for Existing 3D Systems

**34**  
Mbps



**FALCONBRID™**

### New FALCONBRID™ High-speed Image Processor

The newly developed FALCONBRID™ high-speed imaging engine makes possible the simultaneous processing of independent left and right Full HD 1920x1080 images at up to 34 Mbps. The single-chip processor is also responsible for calculating the image displacement and adjusting the parallax for accurate and sharp 3D image recording.

### 64GB Built-in Memory and Memory Card Slot for SDXC/SDHC/SD



### Full HD 3D Recording and Output

JVC's unique L/R Independent format allows 3D footage to be shot at Full HD 1920x1080 resolution at 24p or 50i. The GY-HMZ1E retains compatibility with several other shooting modes, including the widely used Side-by-Side 3D format for conventional AVCHD recording.

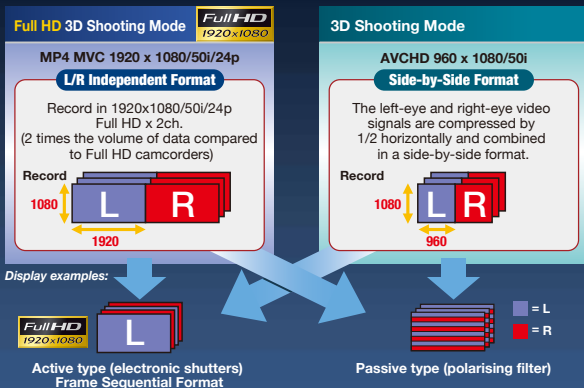

## Edit

Fully Compatible with Major NLE Workflows

### 3D to L/R Conversion

Software supplied with the GY-HMZ1E converts the original 3D footage files into independent left and right image files, which can be ingested into all major NLE systems for efficient 3D editing.

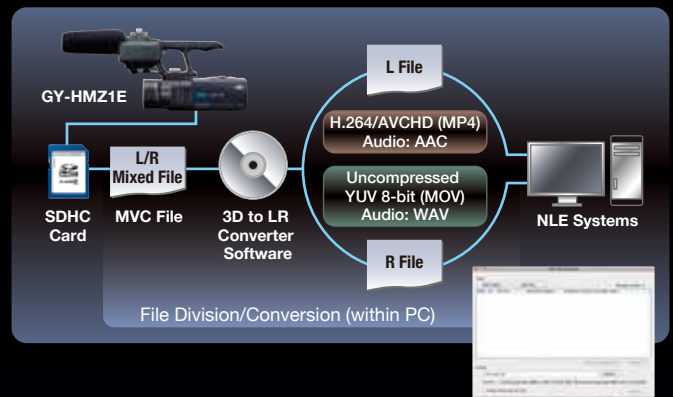

### High Quality AVCHD Recording

The GY-HMZ1E can also shoot high-quality 2D AVCHD-format HD recording at UXP (24Mbps), XP (17Mbps), SP (12Mbps) and EP (5Mbps) modes. The recorded image is 1920x1080/50i Full HD.

### Multiple HDMI™ Output Options

The optimal HDMI™ output format can be selected depending on the application, including Side-by-Side, Frame Packing, Frame Packing for Interlace or 2D.

### Handle with Two XLR Microphone Inputs

A removable handle with two built-in XLR microphone inputs is included.

### Zebra Pattern Select

Switchable between 70–80%, Over 100% and OFF.

### 3.5" Glasses-free 3D Touch Panel LCD Monitor

An on-board 3.5" 920,000-pixel touch panel LCD monitor allows 3D video monitoring without the need for 3D glasses.

### 3D Digital Stills

3D still images can also be captured at up to 2 Megapixel (1920x1080) resolution. 2D images can be captured at 2.9 Megapixel (2304x1296) resolution.

# Specifications

## [Camera]

Image sensor	1/4.1", 3.32M pixels (Back-illuminated) x 2
Lens	JVC 3D TWIN HD GT LENS
Zoom ratios	Optical: 5x (3D) f=3.76 – 18.8mm (35mm conversion: 44.8 – 224mm) F1.2 – 2.28, 10x (2D) f=3.76 – 37.6mm (35mm conversion: 37.3 – 373mm) F1.2 – 2.8 Digital: 200x (2D, max.)
Image stabiliser	Advanced Image Stabiliser (A.I.S.)
Shutter speed	1/2 – 1/4000
Gain	On/Off
Minimum illumination	4 lx
LCD display	3.5" wide, 920,000 pixels

## [Video/Audio]

3D video	MP4 MVC	MPEG-4 MVC/H.264 (JVC original format) HQ (1920x1080x2 24p:VBR 34Mbps) THR (1920x1080x2 50i:VBR 34Mbps) TSR (1920x1080x2 50i:VBR 22Mbps)
	AVCHD	MPEG-4 AVCHD/H.264 TXP (960x1080x2 50i:VBR 17Mbps) TSP (960x1080x2 50i:VBR 12Mbps)
2D video	AVCHD	MPEG-4 AVCHD/H.264 UXP (1920x1080 50i:VBR 24Mbps) XP (1920x1080 50i:VBR 17Mbps) SP (1920x1080 50i:VBR 12Mbps) EP (1920x1080 50i:VBR 5Mbps)
	Audio	3D AAC 2ch, Biphonic 3D sound (when recording using built-in stereo mic) 2D Dolby Digital 2ch

Still	3D	MPF
	2D	JPEG
Recording media	Internal Flash Memory (64GB), SDXC/SDHC/SD Card	

## [Interface]

Video/audio output	HDMI (mini) x1, ø 3.5mm stereo mini jack x1
Audio input	ø 3.5mm stereo mini jack x1 (mic) or XLR x2 (mic)
Headphone output	ø 3.5mm stereo mini jack x1
USB	USB 2.0 (mini) x1

## [General]

Power requirements	DC 11V (using AC adapter) / DC 7.2V (using battery)	
Power consumption	5.1W (3D MP4 MVC HQ mode) / 5.5W (3D MP4 MVC THR/TSR modes) / 4.8W (3D AVCHD mode) / 3.8W (2D mode) * When LCD brightness is set to Normal mode.	
Dimensions (WxHxD)	134x153x234mm (With handle)	
Mass	Approx. 1kg (With handle and battery)	
Temperature	Operating	0°C to 40°C
	Storage	-20°C to 50°C
Humidity	Operating	35% to 80%

## [Accessories Provided]

Battery pack (BN-VF823) x1, AC adapter (AP-V20) x1, Battery charger (AA-VF8) x1, Wireless remote control unit x1, HDMI cable x1, A/V cable x1, USB cable x1, CD-ROM x1

## Video Recording Times

Mode	Format	Recording Mode	Average Bit Rate	Internal Memory	SDXC Card	SDHC Card		
				64GB	64GB	32GB	16GB	4GB
3D	MP4 MVC	HQ	34 Mbps	4hr	4hr 10min	2hr	1hr	10min
		THR	34 Mbps	4hr	4hr 10min	2hr	1hr	10min
		TSR	22 Mbps	6hr 10min	6hr 20min	3hr 10min	1hr 30min	20min
	AVCHD (Side-by-Side)	TXP	17 Mbps	8hr 10min	8hr 20min	4hr 10min	2hr	30min
TSP		12 Mbps	11hr 40min	11hr 50min	5hr 50min	2hr 50min	40min	
2D	AVCHD	UXP	24 Mbps	5hr 50min	5hr 50min	2hr 50min	1hr 20min	20min
		XP	17 Mbps	8hr 10min	8hr 20min	4hr 10min	2hr	30min
		SP	12 Mbps	11hr 40min	11hr 50min	5hr 50min	2hr 50min	40min
		EP	5 Mbps	29hr 10min	29hr 50min	14hr 50min	7hr 10min	1hr 40min

\* The above recording times are approximate. In MP4 MVC HQ/THR modes or AVCHD UXP mode, please use SDHC card with Class 6 or higher performance.

## Dimensions

Unit: mm

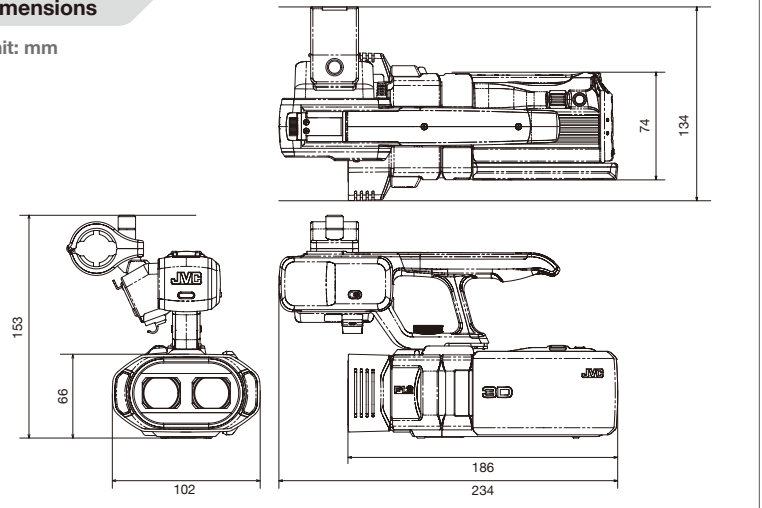

## Optional Accessories



**BN-VF823U**  
Battery



**AA-VF8**  
Battery Charger

"AVCHD" and the "AVCHD" logo are trademarks of Panasonic Corporation and Sony Corporation. Dolby is a registered trademark of Dolby Laboratories. The SD, SDHC and SDXC logos are trademarks of the SD Card Association. HDMI, the HDMI Logo, and High-Definition Multimedia Interface are trademarks or registered trademarks of HDMI Licensing LLC in the United States and other countries. Product and company names mentioned here are trademarks or registered trademarks of their respective owners.

Simulated pictures.

The values for weight and dimensions are approximate. E.&O.E. Design and specifications subject to change without notice.



DISTRIBUTED BY